

**UNIVERSITY OF EDUCATION, WINNEBA**  
**COLLEGE OF TECHNOLOGY EDUCATION-KUMASI**

**DESIGN OF ULTRASONIC BRAKE PAD WEAR DETECTION SYSTEM**  
**FOR CARS**



**ERNEST YAO AGBANYO**

**2021**

**UNIVERSITY OF EDUCATION, WINNEBA**  
**COLLEGE OF TECHNOLOGY EDUCATION-KUMASI**  
**MASTER OF PHILOSOPHY IN AUTOMOTIVE ENGINEERING**  
**TECHNOLOGY**

**DESIGN OF ULTRASONIC BRAKE PAD WEAR DETECTION SYSTEM**  
**FOR CARS**

**ERNEST YAO AGBANYO**

**200030537**

The logo of the University of Education, Winneba, is a circular emblem. It features a central sunburst design with a flame-like top. Below the sunburst are three stylized human figures holding hands. The emblem is surrounded by a banner with the motto 'EDUCATION FOR SERVICE'.

**A Thesis in the Department of MECHANICAL AND AUTOMOTIVE  
TECHNOLOGY EDUCATION, Faculty of Technical Education, Submitted to  
the School of Graduate Studies, University of Education, Winneba, in partial  
fulfillment of the requirements for the award of Master of Philosophy  
(Automotive Engineering Technology) degree**

**NOVEMBER, 2021**

## DECLARATION

### STUDENT'S DECLARATION

I hereby declare that this thesis, with the exception of quotations and references contained in published works which have all been identified and duly acknowledged, is entirely my own original work, and it has not been submitted, either in part or whole, for another degree elsewhere.

STUDENT'S NAME: ERNEST YAO AGBANYO

SIGNATURE : .....

DATE : .....



### SUPERVISOR'S DECLARATION

I hereby declare that the preparation and the presentation of this thesis was supervised in accordance with the guidelines on the supervision of thesis laid down by the University of Education, Winneba.

NAME OF SUPERVISOR: MR. C.K NWORU

SIGNATURE : .....

DATE : .....

## ACKNOWLEDGEMENT

I express my deep and sincere thanks and gratitude to my supervisor Mr. C.K Nworu, (Senior Lecturer), Department of Mechanical and Automotive Engineering Technology College of Technology Education Kumasi for valuable guidance, corrections and encouragement leading to the successful completion of this research work.

I am very thankful to Dr. S.K. Amedorme; College of Technology Education Kumasi for his kind encouragement given me during the period of M.Phil. programme to the completion of this research work.

I express my sincere thanks to Ing. Bernard Forson, (Center Manager); National Vocational Training Institute- Pilot Training Institute- Accra Kokomlemle for granting me permission to use their Electricals/Electronic laboratory for this research work.

I also thank Mr. A.A. Okoe, laboratory assistant at Pilot Training Institute -Accra Kokomlemle for their guidance during simulation and to the staff for their encouragement.

I further thank the staff and friends more especially Automotive Department of Ghana Toyota Company Limited Accra for allowing me to have access to their vehicle manuals.

I deeply indebted to my Parents, Brothers and Sisters, Wife and Children for their abundance love and affection and worthwhile inspiration showed on me during the period of my studies.

To all, I say God bless you.

## **DEDICATION**

I dedicate this research to God Almighty for his love, protection and guidance towards me up to this level of my education.

This research is also dedicated to my children Peace Aku Agbanyo, Cephas Kodzo Agbanyo, Hope Yao Agbanyo.

It is further dedicated to my brothers and sisters more especially Godwin Kwame Agbanyo, Kodjovi Agbanyo, Matthew Kodzo Agbanyo, Christian Coleman Agbanyo and Dora Agbanyo.

It is also dedicated to my loved ones who have help in diverse ways to the success of this research.



## TABLE OF CONTENTS

<i>Content</i>	<i>Pages</i>
DECLARATION	ii
ACKNOWLEDGEMENT	iii
DEDICATION	iiv
TABLE OF CONTENT	v
LIST OF TABLES	vii
LIST OF FIGURES	viii
LIST OF ABBREVIATION	iix
ABSTRACT	x
CHAPTER ONE	1
INTRODUCTION	1
1.1 Background to the Study.....	1
1.2 Statement of the Problem.....	3
1.3 Conceptual framework.....	4
1.4 Purpose of the Study.....	5
1.5 Objectives of the Study.....	5
1.6 Significance of the Study.....	6
1.7 Limitations.....	6
1.8 Definition of Terms.....	7
CHAPTER TWO	9
LITERATURE REVIEW	9
2.1 Introduction.....	9
2.2 Related literature review.....	9
2.2.3 Previous Engineering Design.....	25

2.2.4 New Technological Development.....	25
2.3 Empirical Study .....	27
CHAPTER THREE	29
MATERIALS AND METHODS	29
3.1 Introduction.....	29
3.2 Design Features.....	29
3.3 Arduino Software Coding	31
3.4 Operating Principles.....	34
3.5 Ultrasonic (Proximity) Sensor. ....	36
3.6 Fuel Pump System .....	37
CHAPTER FOUR	38
RESULTS AND DISCUSSION	38
4.1 Introduction.....	38
4.2 Analysis of Results .....	38
4.3 Brake Pad wear Detection parameters .....	41
4.4 Brake pad service life.....	43
CHAPTER FIVE	44
SUMMARY OF FINDINGS, CONCLUSIONS, RECCOMENDATIONS AND SUGGESTIONS	44
5.1 Introduction.....	44
5.2 Summary of findings.....	44
5.3 Conclusions.....	44
5.4 Recommendations.....	45
5.5 Suggestion for future work .....	46
REFERENCES	47

## LIST OF TABLES

Table	Page
Table 4.1. Brake pad wear alert conditions.....	42





## LIST OF FIGURES

<i>Figure</i>	<i>Page</i>
Figure 2.1 Brake pad lining .....	17
Figure 2.2 Brake pad and sensor.....	19
Figure 2.3 Brake pads and sensor .....	26
Figure 3.1 Circuit diagram for designed features. ....	30
Figure 3.2 Circuit diagram for fuel supply line connection.....	31
Figure 4.1 Simulation for first and second conditions of brake pad.....	38
Figure 4.2 Simulation for danger replace brake pad stage.....	39
Figure 4.3 Simulation for interruption of fuel supply line.....	40
Figure 4.4 Simulation for cut off fuel supply line and engine going off.....	40
Figure 4.5 Text message communication to driver/owner of the vehicle on conditions of brake pad.....	41
Figure 4.6 Brake pads wear conditions or parameters.....	42
Figure 4.7 Brake pad wear .....	43

## LIST OF ABBREVIATION

ABS -	Anti-lock Braking System
BMW -	Bavarian Motor Work
CPU -	Central Processing Unit
DC -	Direct Current
FIB-	Focused Ion Beam
GSM -	Global System Mobile
IC -	Integrated Circuit
MCU -	Microcontroller Unit
MTTD -	Motor Traffic and Transport Department
NC -	Normally Close
NO -	Normally Open
NRSA -	National Road Safety Authority
NVTI -	National Vocational Training Institute
PMC-	Polymer Matrix Composite
RAM -	Random Access Memory
ROM -	Read Only Memory
RTA -	Road Traffic Accident
SEM-	Scanning Electron Microscope
SIC -	State Insurance Company.
TEM-	Transmission Electron Microscopy
U.S -	United State
VSM -	Virtual System Modeling
VW -	Volk Wangor
WW1 -	World War 1
WWW -	World Wide Web

## ABSTRACT

Road accidents in Ghana are re-occurring phenomenon. According to the National Road Safety Authority, most accidents can be attributed to brake pad failure or worn-out brake pad. Vehicle safety can be sought through the use of proximity sensors to alert the drivers/owners before the occurrence of any failure due to worn-out brake pad. Hence brake pad wear detection sensor serves as an effective way to enhance vehicle safety in order to reduce rear end-collision accidents. In this study, ultrasonic brake pad wear detection sensor with alert signals was designed to give precautionary measure as a means to reduce road accidents. This study involved the development of software in C language and incorporated into Arduino pro mini (ATmega328p) and microcontroller for sensing and comparing wear status to preloaded value of 1.6mm for hydraulic brake for prediction. The control aspect of the system (sensor) was developed by using proteus virtual system modeling (VSM). The designed circuitry was fabricated and tested in simulated environment. The test results indicated that, during normal operating condition, the led emits green colour signifying that, the brake pad is in good condition. Result also shows that, yellow led emitted signifying approaching danger zone and needed replacement. Furthermore, result predicts that red led indicate interruption of fuel supply line leading to jerking and shutting down of the engine for worn-out brake pad to be replaced. Therefore, it is recommended that every vehicle must be installed with ultrasonic brake pad wear detection system with alert to reduce road accidents caused by worn-out brake pad.

## CHAPTER ONE

### INTRODUCTION

#### 1.1 Background to the Study

Braking system is the single most important safety feature of every vehicle on the road. The ability of the braking system to bring a vehicle to safe controlled stop is absolutely essential in preventing accidental vehicle damage and personal injury. (Sivarao, et al., 2009).

Brake pad is the key component in the braking system which plays a vital role by converting the kinetic energy of the vehicle to thermal energy through friction to bring the vehicle to a stop. Therefore in recent years, vehicle technology has increased tremendously, particularly in relation to braking and sensing systems for safety, comfort and stability experiences. The widespread introduction of anti-lock braking systems (ABS) and active brake sensing apparatus has provided the building blocks for a wide variety of braking control systems.

The braking system is designed with reference to both vehicular requirements and the intrinsic imperatives of the system.

In the case of vehicle-oriented design, the vehicle's center of gravity, and the specified distribution of braking forces between the front and rear wheels determine the amount of braking force that can be applied before wheel lock occurs at any specific level of adhesion between tyre and road surface.

There are several designs of brake action such as mechanical and pneumatic (air) but the research will focus on hydraulic braking design of system-oriented design.

The System-oriented design concentrates on the dimensions of the wheel brakes and on the control devices such as brake pads, pad wear monitor and caliper

piston. Brake pad is such a vital component that is necessarily required when a vehicle is considered. The design is accomplished by disc brake calipers that use hydraulic pressure from the master cylinder to create a mechanical clamping action that forces the brake pads onto the surface of the disc or drum, thereby creating friction as the kinetic energy of the vehicle is converted into heat, its speed decreases and by so doing stopping the vehicle.

The research design will provide a warning system to alert the driver/owner that the brake pads are wearing to avoid brake failure. Further, the design will provide a vehicle braking system and associated method possibility to perform real time active or passive braking control with the motive of eliminating inconveniences such as unwanted vibrations, squeals and unexpected brake failure due to worn out brake pads.

In tribological concept with asbestos as a frictional material, the following properties of a brake pad for the vehicle are generally desirable; high, stable and predictable static and dynamic coefficient of friction, minimum wear characteristics combined with frictional properties that inhibit counter surface wear, adequate corrosion resistance, absence of vibration and squeal noise, acceptable costs of raw materials, processing, and manufacturing technologies.

There are several types of brake pads, depending on the intended use of the vehicle, from very soft and aggressive (such as racing applications) to harder, more durable and less aggressive compounds. Modern vehicle manufacturers recommend a specific kind of brake pad for their vehicle, but compounds can be changed (by either buying a different make of pad or upgrading to a performance pad in a manufacturer's range) according to personal tastes and driving styles.

Asbestos was added as a common ingredient to brake pads post-World War I (WWI), as car speeds began to increase, because research showed that its properties allowed it to absorb the heat (which can reach 200°C) while still providing the friction necessary to stop a vehicle but not strong enough to resist wear.

Brake pads should be checked at least every 25,000km for excessive or uneven wear. Although brake pad wear is unique to each vehicle, it is generally recommended that brake pads be replaced every 25,000km to 75,000km according to Benz, Audi, Haynes and Bosch braking system car manufacturing and service manual. Worn-out brake pads can have many effects on the performance of a vehicle and could cause an accident.

## **1.2 Statement of the Problem**

According to crash reports of Motor Traffic and Transport Department (MTTD) of Ghana Police Service, (2018); National Road Safety Authority (NRSA), (2019); and Oduro, S.D., (2012), survey on assessment and effects of Road Traffic Accident cars in Ghana; all are of the view that, brake-related problems typically cause about 39.5% of all car crashes. They are particularly a problem in rear-end collisions because they make it impossible for a driver to slow down appropriately enough due to worn brake pads, excessive braking distance, unstable brake pads or delay of the driver to hit the brake or effectiveness of the brake pads in gripping the disc or drum. In furtherance to this, the maximum and minimum level of brake pad must be ensured to achieve the effectiveness and efficiency of the brake. Brake pad thickness shall not be less than 3.2mm for air disc brakes, 1.6mm for the hydraulic disc, and 3.1mm for electric brakes. (Haynes, 2021; Haver's, 2021, and Smith Repair guide, 2021).

This research aims at developing ultrasonic brake pads wear detection system (sensor) with alarm to alert the driver of the wear status of brake pads and interruption of fuel supply line for stopping action of the engine of the car.

Furthermore, it is the fact that a recalcitrant driver would ignore warning indicators on the instrument panel which would lead to accident. Therefore the researcher seeks to improve this by designing a system which would indicate the wear rate and automatically stop the vehicle when the driver ignores the warning alert indicators.

The design is intended to have brake pads composed with friction material bound to the surface that faces the disc or drum. It reduces the kinetic energy of the vehicle in conditions when a vehicle has to slow down or stop thus making sure the passengers inside the vehicle are safe.

### **1.3 Conceptual framework**

The design is capable of providing real-time information on the amount of brake pad remaining and alert driver for replacement or change. This system will comprise of an active brake sensor circuit which receive and filter the signal, power supply source to provide electrical power for system use, ultrasonic brake pad sensors (proximity sensor) that would measure the amount of a brake pad left by emitting ultrasonic sound waves through a brake pad to determine various braking conditions including brake pad wear. The reflected sound is then converted into an electrical signal through a solenoid which actuates brakes, and then further sends a signal through the circuit to an indicator in the instrument panel which alarmed follow by text message to alert the driver or owner of the vehicle for brake pads wear as shown in the circuit diagram of designed features in Figure 3.1.

The ultrasonic brake pads wear sensor will be mounted on the brake pad and routed through the caliper in any combination of the four wheels for sensing action. Such mounting of the ultrasonic sensor will assist to reduce exposure of the brake pads to the heat generated when in operation to absorb the kinetic energy of the vehicle.

The system will be equipped with the above devices to respond quickly to engagement and disengagement of the brake to reduce rear end collision.

The system will be designed in such a way that each ultrasonic brake pads wear sensor is operable to monitor the movement of at least one brake block of its corresponding brake unit during actuation or when mechanical force is exerted.

#### **1.4 Purpose of the Study**

The main purpose is to reduce accident caused by excessive brake pad wear through the use of ultrasonic brake pad wear detection sensor, interruption of fuel supply system to stop the vehicle when the driver refused to replace worn out brake pad.

Furthermore, send text messages to the driver or owner of a vehicle on conditions of the brake pad.

#### **1.5 Objectives of the Study**

The aspects targeted in this research are as follows:

- ❖ To design ultrasonic brake pads wear detection sensor with alarm to alert driver on the wear status of the brake pads.
- ❖ To develop a safety unit in conjunction with wear detection sensor to cause automatic engine stopping and wheel locking at specify worn out.



## **1.6 Significance of the Study**

Ultrasonic brake pads wear detection sensors with alarm are an added safety feature to vehicle braking system to warn and alert a driver when brake pads near the end of their service life.

It will provide reliable protection against rear-end collision due to brake failure; also it is cheaper to afford, thereby securing decisive benefits for vehicle users. The Ultrasonic sensors are the eyes of this system.

## **1.7 Limitations**

The initial requirement for this research is to identify and understand the nature of the problem. The problem is related to overcoming brake pads wear as one of the rear-end collision factors in the braking system during emergencies.

In Ghana, there are few modern workshops with brake testing equipment and this limit the researcher's effort. Braking system tools and equipment play a vital role in bringing the vehicle to a stop. Another problem is how to get proximity sensor and arduino pro mini mega 328p. Furthermore financial challenges of moving from one workshop to another for more information and these factors limit this research to Ghana Toyota Company Limited Accra and National Vocational Training Institute (NVTI)-Pilot Training Institute- Accra Kokomlemle. The main target of the ultrasonic brake pads wear detection sensor with alarm is to alert driver of a vehicle to response to brake pads wear changing as a defect during braking when there is an emergency or traffic situations.

## 1.8 Definition of Terms

- i. **Brake pad wear indicator:** This is used to warn the user of a vehicle that the brake pad is in need of replacement. The main area of use for this is on motor vehicles with four wheels.
- ii. **Braking force:** Is defined as the force that slows the car when the driver operates the brake pedal.
- iii. **Wear:** Is a process of interaction between surfaces, which causes the deformation and removal of material on. Causes of wear can be mechanical (erosion) or chemical (corrosion). The study of wear and related processes is referred to as tribology.
- iv. **Wear rate:** Is affected by factors such as type of loading (impact, static, dynamic), type of motion.
- v. **Sensor:** Is a device, module, machine, or subsystem whose purpose is to detect events or changes in its environment and send the information to other electronics, frequently a computer processor. A sensor is always used with other electronics.
- vi. **Ultrasonic sensor:** Is an electronic device that measures the distance of a target object by emitting ultrasonic sound waves, and converts the reflected sound into an electrical signal. Ultrasonic waves travel faster than the speed of audible sound (i.e. the sound that humans can hear). Ultrasonic sensors have two main components: the transmitter (which emits the sound using piezoelectric crystals) and the receiver (which encounters the sound after it has travelled to and from the pads).

Ultrasonic sensors are used primarily as proximity sensors. They can be found in automobile self-parking technology and anti-collision safety systems.

- vii. **Proximity sensors:** Is a sensor that is able to detect the presence of nearby objects without any physical contact. It often emits an electromagnetic field or a beam of electromagnetic radiation and looks for changes in the field or return signal.
- viii. **Adhesion:** Is the tendency of dissimilar particles or surfaces to cling to one another (cohesion refers to the tendency of similar or identical particles/surfaces to cling to one another). The forces that cause adhesion and cohesion can be divided into several types.
- ix. **Centre of gravity:** Is an imaginary point in a braking system where several forces considered being acting.
- x. **Triboluminescent applications:** Is an optical phenomenon in which light is generated when a material is mechanically pulled apart, ripped, scratched, crushed, or rubbed.
- xi. **Transducer:** Is the collective term used for both sensors which can be used to sense a wide range of different energy forms such as movement, electrical signals, and radiant energy, thermal or magnetic energy.
- xii. **Piezoelectric crystals:** Are crystals that produce a potential difference across its opposite faces when under mechanical stress.
- xiii. **Driver alert mechanism;** these are mechanisms that alert the driver on the state of a device.

## CHAPTER TWO

### LITERATURE REVIEW

#### 2.1 Introduction

Effective braking system had been a major concern for manufactures in the past years, therefore various attempt were made to improve braking system to achieve best accident prevention method. At present, brake sensors are widely used on modern vehicles; manufacturers believe that continuous success in the braking system depends on how effective and reliable the brake would be or performed.

This chapter reviews related literature regarding many aspect of the subject matter including brake pad wear indicator, processes, sources and empirical studies, previous engineering design and new technological development.

#### 2.2 Related literature review

According to Hillier & Pittuck, Fundamental of Motor Vehicle Technology (2<sup>nd</sup> Edition, Section 18.1, p.479), a moving vehicle possesses energy of motion which must be converted into some other form of energy in order to bring the vehicle to rest. The speed of conversion governs the rate of retardation of the vehicle. The friction between wheel and pad generates heat; this heat is proportional to the force pushing the pad into contact thus causing wear on the pad. The greater the force applied to the pad, the quicker the vehicle stops, but a limit is reached when the wheel starts to skid over the road due to brake failure or worn out brake pads. Disc brake systems are widely used on cars and commercial vehicles for braking since it development in England 1890s. A disc brake system is basically composed of a caliper with one or more pistons affixed to a wheel hub, a brake disc, and two brake pads. The brake disc is usually made from grey cast iron, which has a high thermal conductivity.

The brake pads are among the most complex ever produced composite materials, as they contain the three main different types of materials, such as metals, ceramics and polymers. This chemical diversity and chemical-physical, makes it very difficult to find the right composition and mixing (Eriksson et al., 2000, Chan et al., 2004).

Brake pads are steel-backed plates with friction material bonded to the surface that faces the disc brake disc. Brake pads convert the kinetic energy of the vehicle to thermal energy through friction. Two brake pads are contained in the caliper, with their friction surfaces facing the disc (Henderson & Haynes, 1994). Brake pads were originally made with organic ingredients, such as asbestos and carbon, held together by a strong resin.

In disc brake applications, there are usually two brake pads per disc, held in place and actuated by a caliper affixed to a wheel hub or suspension upright. Although almost all road going vehicles have only two brake pads per caliper, racing calipers utilize up to six pads, with varying frictional properties in a staggered pattern for optimum performance. Depending on the properties of the material, disc wear rates may vary. The brake pads must usually be replaced regularly (depending on pad material), and most are equipped with a method of alerting the driver when this needs to take place.

According to Towoju, (2019); Braking Pattern Impact on Brake Fade in an Automobile Brake System; brakes are basically devices used in the conversion of kinetic energy to thermal energy. Automobiles generally use the friction type of braking system which consists of a group of mechanical, hydraulic and electronic activated components. The automobile friction type braking system is either the disc or the drum system, and the choice of one is dependent on the purpose it is required to fulfill. The all-disc braking system is made use of in high-performance vehicles, and

rarely will one see the drum braking system used at the front wheels of modern vehicles except on the rear wheels. Automotive disc brakes are usually made of grey iron, and uses calipers to squeeze a pair of pads against a moving/rotating disc thereby causing its retardation as a result of friction. The disc brake is favored over the drum brake system because of its better stopping performance attributable to its better heat dissipation rate, and its better recovery from immersion into liquid. For better heat tolerance, disc brakes can also be manufactured from ceramic composites. However, the impact of cost has limited its use to exotic cars.

Brake fade is caused by overheating of the brake system and results in a temporary reduction or complete loss of brake power, and it is to be avoided. The heat storage and dissipation capacity of the brake system are of utmost importance in the prevention of brake fade which is caused by thermal overload especially during a single stop or repeated stops from a high speed and/or high load condition. The impact of the vehicle speed and duration of braking have been undertaken, and it has been reported that it is imperative that the heat generated must be adequately dissipated to ensure the proper functioning of the system. The relatively low temperature at which materials could fade has been a major reason for consideration in the choice of materials for disc braking systems, because of the very high temperature which is obtainable during braking. Fading is one of the reasons why aluminum, despite being a good thermal conductor and lightweight is not used in its pure form for disc braking system because of its low operating temperature. To ensure fast cooling through forced convection, brake discs are usually also ventilated, however, ventilation of the brake disc can result into the induction of an uneven temperature distribution field in the disc, and by extension Judder effect.

Generally, brake pads could be effective up to a temperature of about  $327^{\circ}\text{C}$  or  $600\text{K}$ , while for racing vehicles, the effective operating temperature of the brake pads without fading can be as high as  $627^{\circ}\text{C}$  or  $900\text{K}$ .

Repeated thermal stresses caused by high temperature usually results into the development of hot spots which subsequently can result into heat cracks on the brake disc surface. Besides the vehicle weight, velocity, and time required to bring the vehicle to a halt or reduced velocity, the braking pattern also contributes to the inception of brake fade. This study is thus focused on the impact of braking pattern on brake system fade using six different scenarios.

According to DIXCEL Company Limited manufactures of brake pads and sensors, the pad wear sensors, also known as pads wear indicators; let the users know when the pads need replacement. There are two different types of pad wear sensors, mechanical and electric. The mechanical type generates a screeching noise when the metal clip attached to the pad comes in contact with the disc, to indicate the need for pad replacement. The electric type turns on a warning lamp on the instrumental panel of the car when the electric wire built into the pad becomes disconnected, to indicate need for pad replacement. Most Japanese and American cars use the mechanical type. Some Japanese luxury cars and most European cars use the electric type. There are two types of electric pad sensors. Bayerische Motoren Werke GmbH or Bavarian Motor Works (BMW) and Mercedes Benz use detachable wears lead wires. The other type is the built-in type, which is used by Volk Wangor (VW) and Audi. The wear lead wire is connected to the brake pad during the manufacturing process, therefore not detachable. By applying pressure to the brake pads, a vehicle with disc brakes slows or stops the disc attached to the wheel hub. When the brake pads wear down, a metal sheet will make contact with the disc and produce a high-pitched squealing

noise. However, if the brake pad wear sensors are mounted, this high-pitched squealing will not occur. If this is the case and the vehicle's brake pads are close to making contact with the disc, a warning light will alert the driver that the brake pads need to be replaced. The sensors will wear out at the same time as the brake pad.

These electronic sensors serve as resistors that connect to a computer module. The sensors are mounted to the brake pad and are designed to maintain frictional contact with the brake disc surface. The mounting interface utilizes a spring clip to hold the sensor in place with a retention force greater than 30N. A vehicle needs to be equipped with two brake pad wear sensors (one in the front wheels and one for the rear wheels), as well as software and algorithms to accurately monitor brake pad wear.

According to White, et al., (2005), when the brake pads or linings have sufficiently worn such that they need to be changed, the wheel and the brake drum have to be removed from the vehicle for the brake lining thickness to be measured. This is cumbersome and time consuming. Visual brake lining wear indicators, such as notches in the lining or color coded layers in the lining, have been used more effectively to determine when the linings should be changed. When a visual wear indicator is used, an inspector can visually examine each brake lining to determine whether it needs to be changed without having to physically measure the thickness. However, the use of these visual wear indicators can also be cumbersome and time consuming because they require the inspector to visually check each lining while the vehicle is stationary. Thus, it is desirable to have an efficient way to continuously monitor the brake lining thickness during the operation of the vehicle to determine whether the brake linings need to be replaced without having to visually inspect each brake lining. As larger-type of wheeled vehicles such as eight (8), 10 or 12 wheeled



trucks have increased in size, weight and load carrying capacity it has become increasingly important for the truck driver to have an ongoing knowledge of the effectiveness of the braking system during the braking process. Additionally, the truck driver has a need for ongoing information/data on the state of readiness of all of the braking components/parts, particularly in terms of temperature and wear at all times during truck operation.

According to Hanisk, et al., (2008), discloses a resistive brake lining wear and temperature sensing system. This system includes a brake lining temperature and wear sensor having a plurality of serially connected wire loops and a resistive temperature sensor having a lower range of resistance than any one resistor mounted in a cavity formed in the brake lining where a plurality of resistors are connected one to each wire loop to be sequentially connected to a sensor circuit as the brake lining wears and breaks each wire loop. A control unit provides an electrical current to the sensor circuit and monitors the electrical potential across the plurality of wire loops and the resistive temperature sensor and then generating an output signal representing the temperature and wear of the brake lining. This prior art patent does not disclose or teach the brake monitoring and sensor system of the present invention.

According to Adeseko & Kareem, (2018), (p. 226-231); Non-disposable Brake Pad Sensor; road traffic injuries and deaths are a growing public health concern worldwide. Studies have shown that road traffic injuries are a major cause of death and disability globally, with a disproportionate number occurring in developing countries. The immediate cause of a road accident may also be attributable to mechanical factor and carelessness in the form of omission to check and maintain the vehicle at the appropriate time.

Howell, et al., (2008), invented a brake pad prognosis system for estimating the thickness of a vehicle brake pad as it wears from use. When the thickness of the brake pad becomes sufficiently small, a mechanical scrapper makes an annoying high frequency noise which is an unfriendly reminder that the brake pad needs to be replaced. Although, the noise does alert the vehicle operator that the brake pad is worn out, it does not give the vehicle operator advanced warning, or a continuous determination of the pad thickness, only that the brake pad has worn down to a low level.

Baldwin & White, (2020), invented a resistive wear sensor. This invention relates to resistive wear sensors that are used to provide given indications that wear in a component has reached a specific point (the wear point). The invention is particularly concerned with wear sensors of the type that undergo a specific change in resistance at a given wear point; enabling an electrical detection circuit connected to the sensor to respond to the change in resistance. The drawback with this type of sensor is that false wear point signals can be generated by open circuit failures.

According to publication on September 29, (2005), a brake pad in a disc brake system is adapted to be moved against a rotating brake drum or disc brake disc. Thus, there remains a need for a reliable method and device for measuring brake wear and monitoring brake temperature in either of the foregoing brake systems using simple temperature sensors and a simple monitoring/controller unit. It should be noted that the present invention is equally applicable to either drum brake systems or the disc brake systems.

Some prior art systems have monitored brake lining thickness on vehicles by using a single thermistor sensor in the lining which changes its electrical resistance based on temperature.

Brake lining wear for this system is calculated based on changes in measured resistance of the thermistor. Such systems can often be ineffective and produce inaccurate results. Other systems have monitored the temperature of the brake linings to compare these temperatures to electronically stored standard characteristics for the brake lining. These systems are complicated and vary from lining to lining due to varying characteristics in lining materials and configurations.

Other prior art monitoring systems have the wear sensors embedded and inserted within the brake pad, and as the brake pad wears out these wear sensors are destroyed in the process. Thus, it is desirable to have a sensor system having a simple temperature indicator and lining wear indicator which can be used universally on all brake linings and which calculates accurately the remaining useful thickness of brake lining material.

Furthermore, various attempts were made in the past to improve braking systems to achieve best accident prevention methods. This includes the existing systems in current automobile industries and the novel approaches published in literatures were reviewed. The existing approaches in preventing accidents is Honda's idea of Anti-lock Braking System (ABS) which helps the rider get a hassle free braking experience in muddy and watery surfaces by applying a distributed braking and prevents skidding and wheel locking. Volvo's new launch XC60 SUV will sport laser assisted braking which will be capable to sense a collision up to 50mph and apply brakes automatically.

Existing Methods of Accident Preventions are:

### **2.2.1 Pre-Sense Plus**

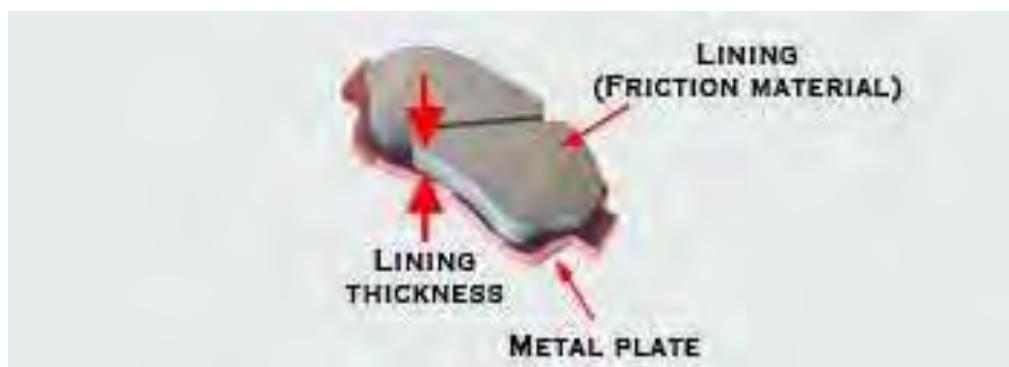
The full version of the system (Pre-Sense Plus) works in four phases. In the first phase, the system provides warning of an impending accident, while the hazard

warning lights are activated, the side windows and sunroof are closed and the front seat belts are tensioned. In the second phase, the warning is followed by light braking, strong enough to win the driver's attention. The third phase initiates autonomous partial braking at a rate of  $3\text{m/s}^2$ . The fourth phase decelerates the car at  $5\text{ m/s}^2$  followed by automatic deceleration at full braking power, roughly half a second before projected impact.

### 2.2.2 Pre-Sense Rear

A second system, called (Pre-Sense Rear), is designed to reduce the consequences of rear-end collisions. The existing approaches in preventing accidents are Honda's idea of Anti-lock Braking System (ABS).

According to Sivarao, et al., (2009); An investigation toward development of economical brake lining wear alert system; The disk braking system uses brake pads with lining as shown in Figure 2.1, where semi-metallic linings are used in common because of their ability to withstand higher operating temperatures. The lining is riveted, bonded, or mould-bonded to the pad backing. The trailing end of a pad is always hotter than the leading end, and therefore that region wears more rapidly and causes excessive taper wear which leads to excessive flex and a low brake pedal.



**Figure 2.1 Brake pad lining**

This research is aimed to determine the capability of using micro sensor to detect the wear limit of a brake pad lining. Brake pads from two established Malaysian manufacturers namely M and A (abbreviated to prevent disclosure of the manufacturers) were selected to make comparative analysis to mount the sensor on the better one. The current problem faced by the vehicle owners are, they do not know condition of the brake pads, whether there are still good or need to be replaced. Even, one is scheduled for the periodical replacement, yet there will be cases where they are replaced when actually the linings are still in good condition. If the linings are used without replacement after the lining exceeds its safety wear limit, the backing plate of the pad will damage the disc which would cause the newly replaced lining to wear at faster rate due to the disc's rough surface. Therefore, the disc has to be skimmed and when the disc undergoes skimming process, it loses its mechanical properties which will easily deform or damage its originality. Prior to that, the skimmed disc will be thinner and impact of inertia while moving will affect the brake associated parts which may bring disaster to the user due to rapidly reduced braking performance and efficiency.

At the moment, Proton Perdana V6 users are alerted by mechanical noise which produced by mechanical touch sensing technique using spring steel when the safety wear limit is reached. Unfortunately, this system alerts only when the car is on move and secondly, when the car is on move, rarely the alert reaches driver's ear.

According to Technical Bulletins by Raybestos Bulletin 18-13,(2018), on vehicles with brake pad wear sensors / original pad wear indicator; the original pad wear indicator was actually integrated into the brake pad itself. In fact, many manufacturers still use this pad wear indicator today. The indicator is actually a piece of metal connected to the pad's backing plate or shim. The piece of metal protrudes

about two to three millimeters past the backing plate. When the pads wear down past two to three millimeters, the metal will make contact with the disc. This produces a high-pitched squealing noise. That squeal tells the driver that it is time to take their vehicle in for a brake job.



**Figure 2.2 Brake pad and sensor**

According to Markel, A. (2016), brake pad wear sensors have been around for more than 40 years. But in the past decade, they have evolved so that brake wear can be estimated. This has allowed the driver to pick the right time to have their brake pads replaced.

According to Markel, A. (2020), drivers typically “never notice that their brakes are bad” until the grinding noise or failure to stop makes them realize that something is wrong. Even with built-in wear indicators, they are often overlooked. Today’s modern wear sensors work with the entire brake system and can estimate the amount of brake pad remaining. This allows the customer to pick the right time to have the braking components replaced. Electronic brake pad wear sensors can be found on a variety of vehicles, including domestics like Cadillac and Chevy. Also, brake pad wear sensors can be found on BMW, Porsche, Mercedes Benz and Audi vehicles. These give a more accurate reading on brake pad depth compared to squealer metal tabs that make noise that most drivers manage to ignore assuming it will go away over time.

According to Shailendra, et al., (2019); Smart Braking System Using Ultrasonic Sensor and Actuator; Electronic brake pad wearing sensor eliminate the tab by using a small sensor - a loop of wire with a low current passing through it. As the pad wears out, the loop is exposed and makes contacts with the rotor or disc, creating an open circuit. However, the amount of time it takes to do this can vary greatly. Road conditions, driving style, speed, load, and the type of pads and discs can all impact the speed at which this happened, making it's difficult for drivers, and technicians to determine when a new set may be needed. The introduction of the brake pad wear sensor removes this uncertainty by letting drivers know when the pad has worn and in some cars even predicting as well as helping plan for future brake jobs, it also ensures the brake pads are in good working order for a safe and controlled ride.

According to Harshal, et al., (2021); Infra-Red (IR) based microcontroller sensors were used to detect the brake pad wear. The IR sensor is placed near the brake pad, connected to the microcontroller. The distance between brake pad and brake disc decreases continuously while wearing out. The distance is the main parameter that is sent to the micro controller. When the distance falls below certain specified limit, the micro controller activates the warning system at the instrument panel (dash board). It constantly monitors the condition of the brake and gives continuous feedback. This system is good but does not stop the vehicle from moving, therefore allow room for recalcitrant drivers to operate. Also integrating the sensor with the brake pad by drilling a hole of required depth. The hole is drilled when the hardness is maximum. The place to drill the hole is selected based on result of hardness tests. The depth of hole is based on brake pad's initial thickness and the thickness where the driver should be warned. For the test purpose, micro switch was used. The difference in

resistance is measured when the sensor wire wears out due to friction. After carrying out few test runs, the authors successfully did the sensing of brake pad with proper functioning of micro switch and the embedded sensor in the brake pad still has some drawback such as the hole has taken the topographical surface and therefore reduces the efficiency of the brake.

According to Hattwig, P. (2000), maintenance is required as a preventive measure to keep a vehicle in a roadworthy and stable condition. In other words maintenance and attention are employed to either retard the inevitable wear of parts or to replace worn parts with new ones. The brakes are the important to vehicle roadworthiness and the brake linings and pads play a special role as wearing parts. The inspections specified at regular intervals are not helping the system. In regard to disc brakes, it can be advantageous to indicate the wear of the pads by means of a warning device to indicate the wear rate to reduce the visual and interval inspection of brake pads.

According to Karim, N. (2000), the most common type of service required for brakes is changing the pads. Disc brake pads usually have a piece of metal on them called a wear indicator. When enough of the friction material is worn away, the wear indicator will contact the disc and make a squealing sound. This means it is time for new brake pads. There is also an inspection opening in the caliper so you can see how much friction material is left on your brake pads. Sometime, deep scores get worn into brake disc. This can happen if a worn-out brake pad is left on the car for too long. Brake disc can also warp; that is, lose their flatness. If this happens, the brakes may shudder or vibrate when you stop.

According to Kanishq & Parth, (2018); Automatic Brake Pad wear Indicator is an integrated system that can be used in modern cars to provide user with instant data



on brake pad condition. The sensors used will be placed at defined locations of concern which would fetch the information about the condition of brake pad.

Electronic Control Unit (ECU) as our main board and sensor will collect all the real time data from environment and processed by the concerned output mechanism.

During the research, it was found that there exist two main problems with the pre-existing system is that does not give us a visual indication of brake pad wear, the system does not give a pre indication of brake pad wear.

The aim behind this research was to develop a retrofit which can be fitted aftermarket and also can be used in cars with manual transmission. Current (eddy current) flows in the target due to electromagnetic induction. As the target approaches the sensor, the induction current flow increases, which causes the load on the oscillation circuit to increase. Then, oscillation attenuates or stops. The sensor detects this change in the oscillation status with the amplitude detecting circuit, and outputs a detection signal.

According to Kyrtos, brake lining wear indicator utilizes a temperature Sensor assembly embedded in a brake lining of a drum brake assembly. The temperature sensor assembly includes two temperature sensors with a first temperature sensor located at a first distance  $X$  from the wear surface of the brake lining and a second temperature sensor located at a second distance  $X-d$  from the wear surface. A timing device measures the time period for the first temperature sensor to reach a first predetermined temperature and measures the time period for the second temperature sensor to reach a second predetermined temperature. Thus, the wear indicator provides a time-temperature based determination of when the brake linings should be replaced. This prior art patent does not disclose or teach the brake monitoring and sensor system of the present invention.

According to Sarvendra, et al., (2013), this work is meant to study the tribological properties difference of potentially new designed non-commercial brake pad materials with and without asbestos under various speed and nominal contact pressure. Binder resin and reinforcing fibers used in friction materials have substantial influence in casual the friction characteristics. Frictional heat generated during the brake application can easily raise the temperature at the interface beyond the glass change temperature of the binder resin resulting in an abrupt change in the friction force during braking. Brake pads change the kinetic energy of the car to thermal energy by friction. Two brake pads are controlled in the brake caliper with their rubbing surfaces facing the disc. When the brakes are hydraulically applied, the caliper clamps or crushes the two pads composed into the spinning disc to slow/ stop the vehicle.

According to Shubham, et al., (2021), braking is certainly system of a car one of its more important features. The aim of this effort is to create a better braking system with indicator. Brake disappointment occurs only because of worn out of brake shoe and cut in liner. It consist two sensors. One sensor is connected with the brake shoe. The second sensor is the brake liner. The sign from the two sensors is given to a microcontroller. When the brake shoe is damaged out, the sensor senses signal to the microcontroller. Also, if the brake liner is cut, the sensor directs signal to the microcontroller. The microcontroller analyses the signal and operates the conforming indicator. It nothing mistaken, the vehicle will move and if any one critical, the vehicle will stop and the screen shows the indication of brake failure. Since this specifies the status of the brake, the user can identify the condition of the brake and thus limiting the chances of malfunction.

According to Eriksson, M. (2002), on investigation of surface characterization of brake pads after running under silent and squealing conditions, indicated that pads with many small contact plateaus have a larger tendency to generate squeal than pads with a few large plateaus. Moreover in the silent pressure interval, the size of the contact plateaus increases rapidly with brake pressure neglecting that the sound does not reached the driver.

According to Lee, et al., the uniformity of pressure distributions could affect the squeal occurrence. This was suggested by the results that the higher contact area of the pads the lower the squeal index. This call for further studies on brake squeal and its contact analysis.

According to Osterle & Urban, using Focused Ion Beam technique, where, it was used to characterize superficial layers at micro-contact area of a commercial brake pad. The friction material was a polymer matrix composite (PMC) with approximately 50% metal content (semi metallic) and the counter part was a cast iron rotor. Experiment depending on the constituent of the pad, one, two or three layers were identified. The experiment is show that the FIB technique provides additional information which in combination with the more conventional technique (LM), (SEM) and (TEM) increases the knowledge on the role of third body formation and superficial layers on brake pads.

According to Mat Lazim, et al., (2018), investigated brake pads with different compositions by using small-scale friction testing device. However, the high cost and complex design requirements of these devices limit their usage in determining to the full scale the wear rate of brake pads.

According to Osterle, et al., (2001), in fact brake pad material should maintain a relatively high, stable and reliable friction coefficient at a wide range of braking

conditions, temperature, and humidity. But during braking or extreme force deceleration, the highest concentration of brake wear particles emitted into the atmosphere. During braking operation, both brake pad and counter face disc wear out creating discomfort leading to accident. This cause for alerting system to indicates the conditions of the brake pads.

### **2.2.3 Previous Engineering Design**

Most older brake pad wear systems had a sensor at each corner of the vehicle on the inboard pad. These systems can vary in the number of wheels that have sensors and where the placement is on the pads. Since the 1970s, these have been just a loop of wire with a small amount of current running through it. On these older systems, the sensor itself had a known resistance exceeded 2,000 ohms, a rectifier circuit in the instrument cluster sensed it as an open circuit and turned on the light. The most common failure for these types of circuits was physical damage and corrosion at the connector. These systems are typically better than squealer-type wear sensors that require the driver to hear the brake noise.

### **2.2.4 New Technological Development**

Modern brake pad wear sensors can do more than just warn the driver of a worn brake pad. These new wear sensors work with the rest of the brake system and can estimate the mileage until the brake pads wear out.

New wear sensors have two resistor circuits in parallel at two depths. The first resistor circuit is set at a higher position in the sensor, and the second resistor circuit is at a lower position. When the first resistive circuit is broken, the resistance in the

sensor will increase due to the resistors having a parallel structure. When the second wire is broken, the circuit is now open.

The first resistive circuit will not typically set a warning light. The information is used by the brake system to estimate the pad life remaining using other information called two-stage wear sensors, these are monitored by the ABS module and instrument cluster module on some vehicles.

The system wear sensors use information such as wheel speed, mileage, brake pressure, brake disc temperature and brake operating time to determine the life remaining on the pads. This is displayed in the information center or with a warning lamp that may glow from yellow to red. Some systems may show the life left on the pads during start up.

The old trick of splicing the wires together to bypass the warning light will not work with two-stage sensors. The module passes voltage through the circuit and uses the amount of voltage drop to confirm the sensor is working. If the system notices that no voltage is dropping across the circuit, it will set a malfunction warning light.



**Figure 2.3 Brake pads and sensor**

### 2.3 Empirical Study

The automotive industry has seen a rise in consumer demand for vehicle safety features in different weather and environment conditions. This becomes more important for road users and fleet managers in terms of automated driving leading to various invention by other researchers such as, Howell, et al., (2005), Baldwin & White, (2020); Sivarao, et al., (2009); Markel, A. (2021) on development of economical brake lining wear alert system. Their invention has been shown in the related literature reviews with drawbacks of each invention.

The systems researchers' drawbacks such as the manufactured central groove eventual disappeared due to wear to indicate the end of a pad's service life and the alerting sound is only activated while the car moves and it stops, and rarely the alerting sound does not reach the driver according to Hanisk, et al., (2008).

Visual inspection, removing the wheel and disc for measuring the thickness of the pads physically is cumbersome, time consuming and can be ignored by the driver leading to endangering life of occupant in the vehicle and damaging of braking system components such as the piston, caliper, disc and the hydraulic hose according to White, et al., (2005).

In general, friction layer of brake pads is important for maintaining a stable and consistent coefficient of friction. The brake pads must have a coefficient of friction between 0.3 and 0.4, according to DIXCEL Company Limited. The higher the coefficient of friction, the less fluid pressure (lighter push of the brake pedal) is required to create a high braking force. If the coefficient of friction is too high, there is too much friction and makes it very difficult to brake. The most important factors for the coefficient of friction is for the brake pads to reach its maximum friction level immediately after the brake pedal is stepped on by so doing response to retardation.

According to Adams, F. (2005), Some prior art systems have monitored brake pad thickness on vehicles by using a single thermistor sensor in the pad which changes its electrical resistance based on temperature. Brake pad wear for this system is calculated based on changes in measured resistance of the thermistor. Such systems can often be ineffective and produce inaccurate results. Other systems have monitored the temperature of the brake pad to compare these temperatures to electronically stored standard characteristics for the brake lining. Thus, it is desirable to have a sensor system having a simple temperature indicator and pad wear indicator which can be used universally on all brake pad and which calculates accurately the remaining useful thickness of brake pad material.



## CHAPTER THREE

### MATERIALS AND METHODS

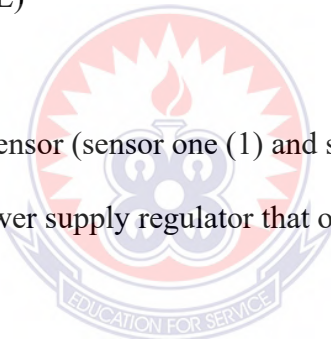
#### 3.1 Introduction

This chapter seeks to deal with the circuit design process, hardware building, software programming, operating principles and materials of the ultrasonic brake pads wear detection sensor (proximity sensor) with alarm follows by text messages to alert the driver of wear status of the brake pad.

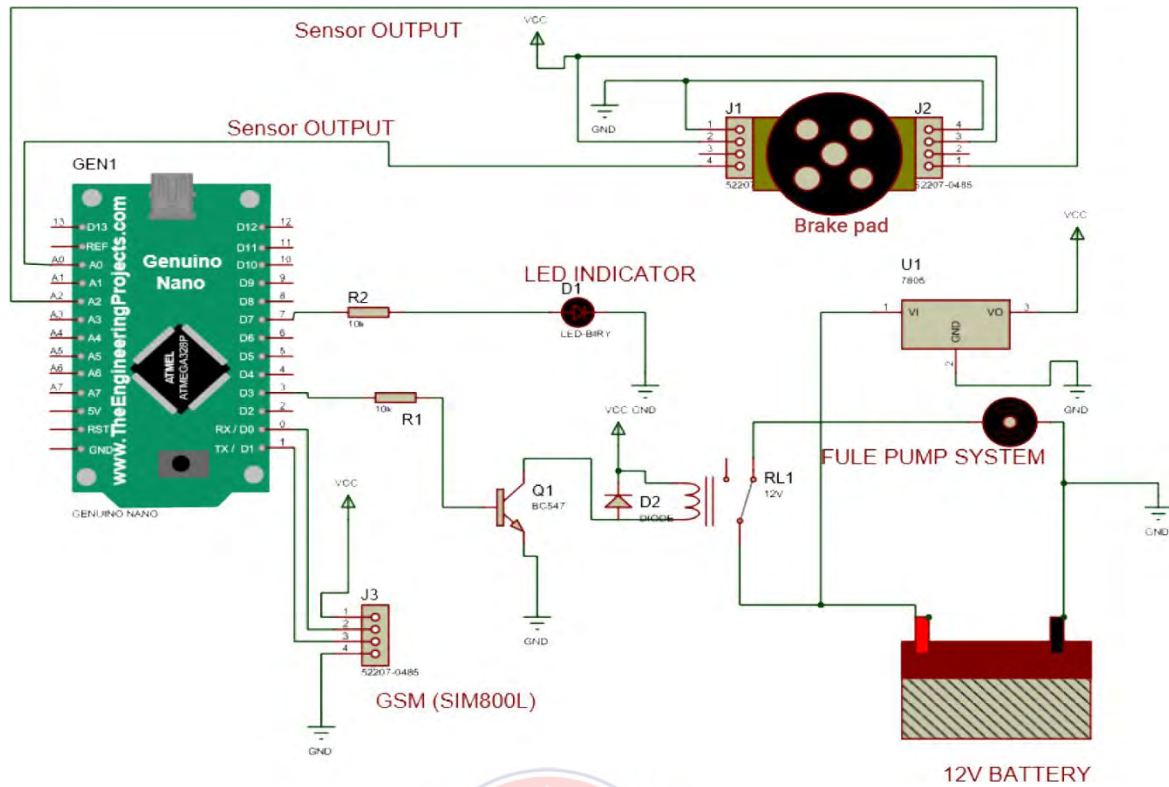
#### 3.2 Design Features

The system comprises of the following components as designed features:

- ❖ Arduino pro mini (ATmega328p)
- ❖ GSM module (sim800L)
- ❖ Relay
- ❖ Reflective proximity sensor (sensor one (1) and sensor two( 2)
- ❖ Lm7805 is a linear power supply regulator that outputs +5volts
- ❖ Led indicator
- ❖ Brake pad
- ❖ Fuel pump system
- ❖ Diode
- ❖ Battery





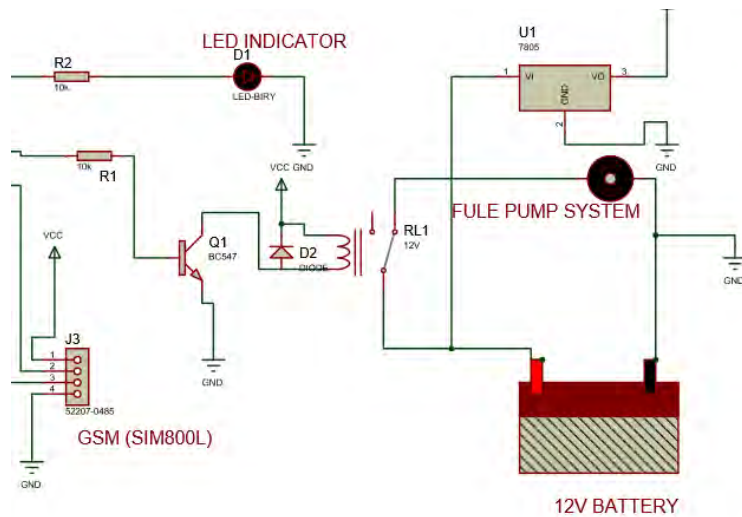


**Figure 3.1 Circuit diagram for designed features.**

Due to the architecture of this research as shown in the diagram in Figure 3.1. The design process was purposely divided into two main phases to achieve the specific objectives of the research.

The first phase was used to simulate using proteus virtual system modeling (VSM) for the hardware part and software is then by using Arduino IDE. The source code file obtained from the development environment in C language was added to the microcontroller programme memory and the simulation initiated.

The second part was to design the electronic aspect of the power supply unit and other components for text messages, interruption of fuel supply line and stopping of the engine follows by locking of the wheels as shown in the diagram in Figure 3.2.



**Figure 3.2 Circuit diagram for fuel supply line connection**

### 3.3 Arduino Software Coding

The arduino software coding is written in C language programme and fed inside the arduino pro mini ATmega328p to help shows the result of brake pad wear distance calculations at each stage.

```
#include<softwareSerial.h>
```

```
Const int sensor A0;
```

```
Const int sensor2 A1;
```

```
Int redled = 12,
```

```
Int greenled = 11;
```

```
Int buzzer = 4;
```

```
Int relay = 7;
```

```
//Create software serial object to communicate with SIM800L
```

```
SoftwareSerial mySerial(3,2); //SIM800L Tx & Rx is connected to Arduino #3 & #2
```

```
Void setup()
```

```
{
```

```
pinMode(redled,OUTPUT);

pinMode(greenled,OUTPUT);

pinMode(buzzer, OUTPUT);

pinMode(sensor,INPUT);

pinMode(sensor2,INPUT);

pinMode(relay,OUTPUT);

//Begin serial communication with arduino and Arduino IDE (Serial Monitor)

Serial.begin(9600);

//Begin serial communication with Arduino and SIM800L

mySerial.begin(9600);

Serial.begin(9600);

Serial.println(Initializing...");

Delay(1000);

mySerial.println("AT");/

updateSerial();

mySerial.println("AT+CMGF=1"); // Configuring TEXT mode

updateSerial();

mySerial.println("AT+CNM1=1,2,0,0,0"); // Decides how newly arrived SMS
messages should be handled

updateSerial();

}

Void loop()

{

Int value=analogRead(sensor)

Serial.print (value);
```



```
Int Svalue=analogRead(sensor)

Serial.print (value);

If (value = 200)

{

digitialWrite(greenled,HIGH)

}

else if (value<100 && value ==50)

{

digitialWrite(redled,HIGH)

mySerial.println("AT+CMGF=1"); // Configuring TEXT mode

updateSerial();

mySerial.println("AT+CMGS=\"+233277161488\"");//change ZZ with country code

and +2330249394663 with phone number to sms

updateSerial();

mySerial.write(26);

}

}

Void updateSerial()

{

Delay(500);

While (Serial.available())

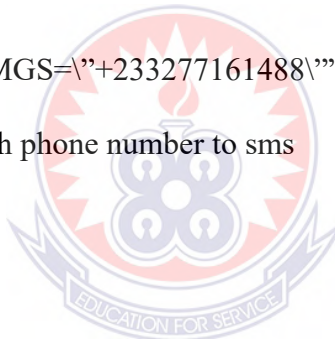
{

mySerial.write(Serial.read());//Forward what Serial received to Software Serial Port

}

}

While(mySerial.available())
```



```

{
Serial.write(mySerial.read()); //Forward what Software Serial received to Serial port
}
}

```

### 3.4 Operating Principles

The ATmega328p in Figure 3.1 is a microcontroller; the microcontroller is defined as microcontroller unit (MCU); is a small computer on a single metal-oxide-semiconductor (MOS) integrated circuit (IC) chip. A microcontroller contains one or more central processing unit (CPUs) (processor cores) along with memory and programmable input/output peripherals. Programme memory in the form of ferroelectric random access memory (RAM), NOR flash, or read-only memory (OTP ROM) is also often included on-chip, as well as a small amount of RAM. Microcontrollers are designed for embedded applications, in contrast to the microprocessors used in personal computers or other general-purpose applications consisting of various discrete chips.

The mega328p in this research is acting as the main controlling unit of the system which will send and receive instructions from other components connected to its ports. Pin A-zero (0) and A-two (2) are connected to sensor one (1) and sensor two (2) which is proximity sensor; both sensors read the thickness of the brake pads as shown in Figure 3.1. If any of sensors bring information below the actual thickness of the brake pad which is 1.6mm of both side of the brake pad. This information is then send back to the microcontroller to make a decision.

The microcontroller in Figure 3.1 is acting as (Tx and Rx) connect to the global system for mobile communications (GSM) which do the text messages

(calling) when information from the two proximity sensors connected to pin zero (0) and pin one (1) detects the distance between the ending value of the brake pad. The measured value will be compared with the set point of 1.6mm. When this set point is meant, the microcontroller will then send information to the (GSM) to activate and send a text messages together with alarm alert which read as; danger replace brake pad, interruption of fuel supply lines due to excessive brake pad wear, vehicle will stop in the next 50km if brake pad not replaced, to the instrument panel for the driver to see, read and act. These messages will continue to flush in the driver's instrument panel (dash board) until the brake pad is changed.

The system will wait for some few seconds if the set point is still the same, then the system will trigger the relay (connected to pin three (3) of the microcontroller) to intermittently open the connection of the fuel pump after the second message if the driver continue to ignore the first text message follow with yellow light.

The fuel supply line will be permanently opened stopping the vehicle until the brake pad is replaced after the interruption message. When the brake pad is replaced, the relay system will trigger back to connect for the fuel pump to supply fuel for the engine to start.

Figure 3.1 further shows the connection of the relay with the pumps, the concept for a relay to operate. Since the relay has a 5V trigger voltage, the researcher used +5V DC supply to one end of the coil and the other end to ground through a switch. The switch used in this research is transistor and microcontroller. The microprocessor can also be used to perform switching operation. The diode connected across the coil of the relay is called the Flyback Diode. The purpose of the diode is to protect the switch from a high voltage spike that can be produced by the relay coil. As

shown one end of the load can be connected to the common pin and the other end is either connected to normally open pin (NO) or normally closed pin (NC). If connected to NO the load remains disconnected before trigger and if connected to NC the load remains connected before trigger.

### **3.5 Ultrasonic (Proximity) Sensor.**

Proximity sensor is defined as a non-contact sensor that detects the presence of an object referred to as the “target”. When the target enters the sensor’s field depending on the type of proximity sensor, sound, light, infrared radiation (IR), or electromagnetic fields may be utilized by the sensor to detect a target. The two most commonly used proximity sensors in this research are the inductive proximity sensor and the capacitive proximity sensor.

Inductive proximity sensors are contactless sensors used to only detect metal objects. It’s based on the law of induction, driving a coil with an oscillator once metallic object approaches it. The researcher chooses proximity sensor because of contactless detection, environment adaptability; that is resistant to common conditions seen in industrial areas such as dust and dirt, capable and versatile in metal sensing, considerably cheap when it comes to price and no moving parts thus ensuring a longer service life.

Capacitive proximity sensors are also contactless sensors that detect both metallic and non-metallic objects, including liquid, powders, and granular. It operates by detecting a change in capacitance.

Furthermore, Inductive, Capacitive, Ultrasonic, IR as the common proximity sensors used in this research for varying applications such as distance measurement, and

brake pad wear detection. Hence, picking one that's easily connectable, accurate, and reliable is very much important for fulfilling the intended usages.

### **3.6 Fuel Pump System**

The fuel supply system is to store and filter the required fuel, and to provide the fuel-injection system with fuel at a specific supply pressure in all operating conditions. Furthermore, this operation will be curtail if the fuel supply line is opened by the triggering the relay due to excessive worn brake pad thus causing the engine to stop running and wheel locking.





## CHAPTER FOUR

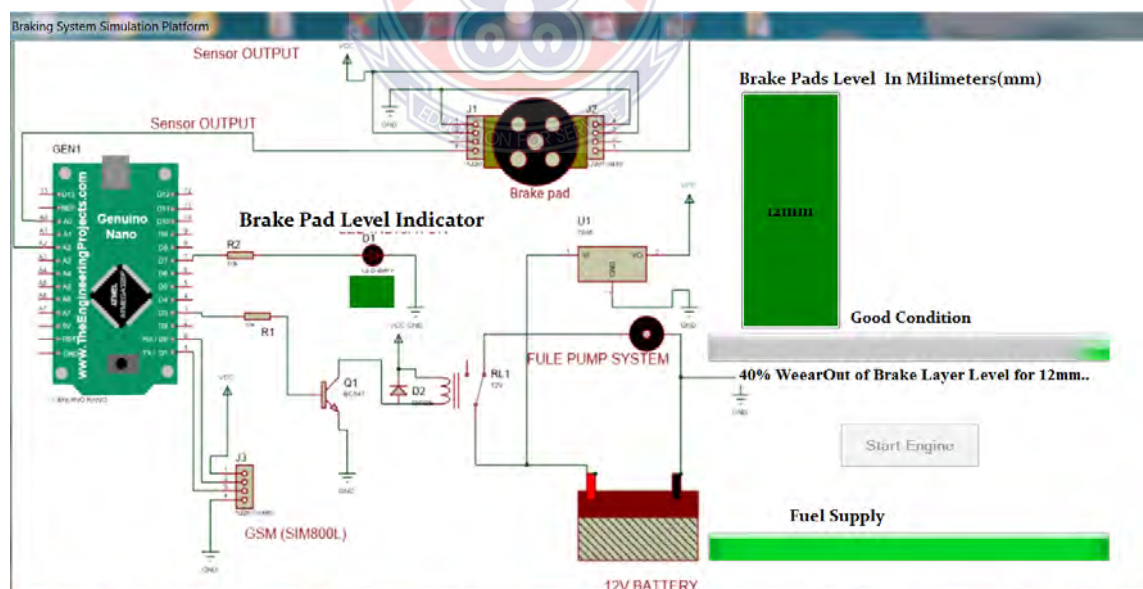
### RESULTS AND DISCUSSION

#### 4.1 Introduction

This chapter seeks to deal with the results and analysis of the design of the used of ultrasonic brake pad wear detection system with alert.

#### 4.2 Analysis of Results

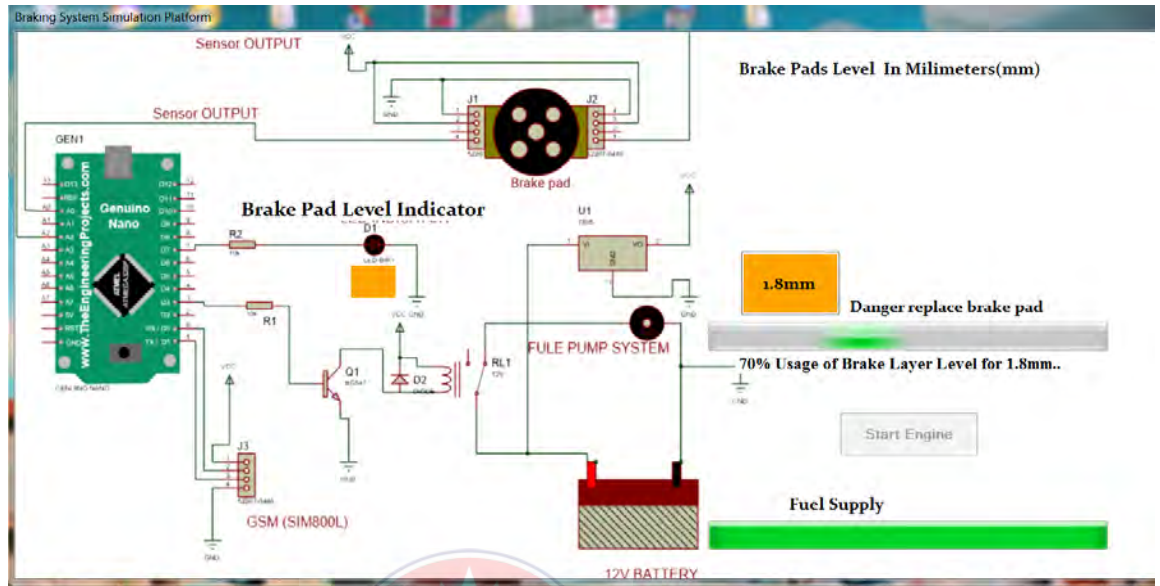
After simulating Figure 3.1 in accordance to the five parameters or conditions of the brake pad as shown in Figure 4.6 and Table 4.1, using proteus virtual system modeling and micro soft visual studio 2013, results show that, the actual brake pads thickness is 12mm, and at 40% usage, green led indicated in the instrument panel, fuel continue to flow indicating that the brake pad is in good condition for first and second stages in Figure 4.1.



**Figure 4.1 Simulation for first and second conditions of brake pad**

Furthermore, it was also observed that, once the indicator started to glow from yellow to red at 70% usage with a value of 1.8mm, fuel continue to flow and the brakes were

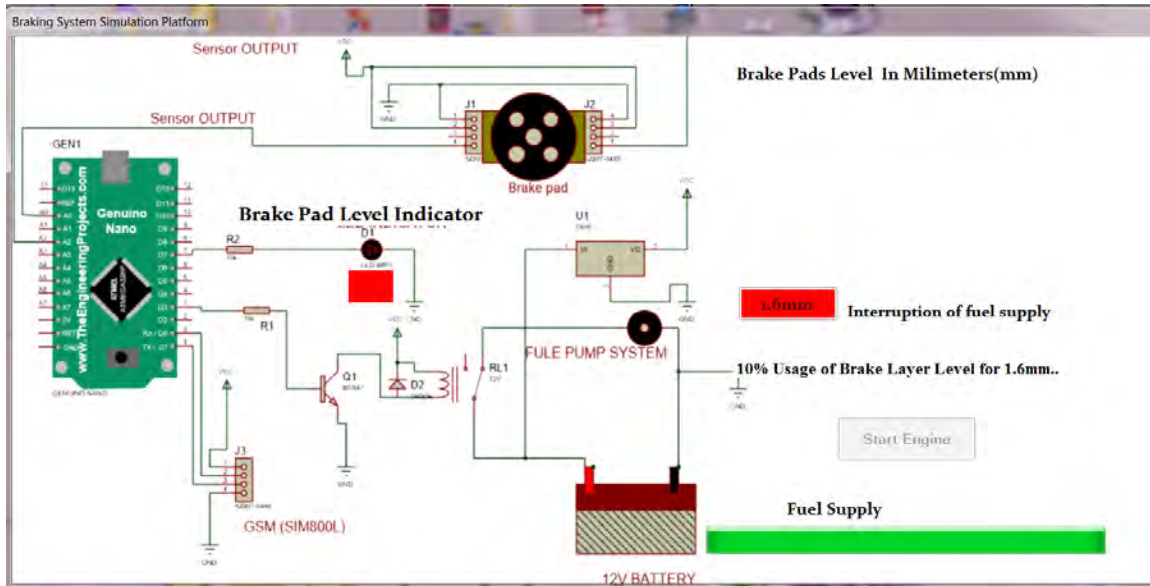
not as efficient as they were before and the stopping distance had increased and during traffic situation will lead to rear-end collision as shown in Figure 4.2.



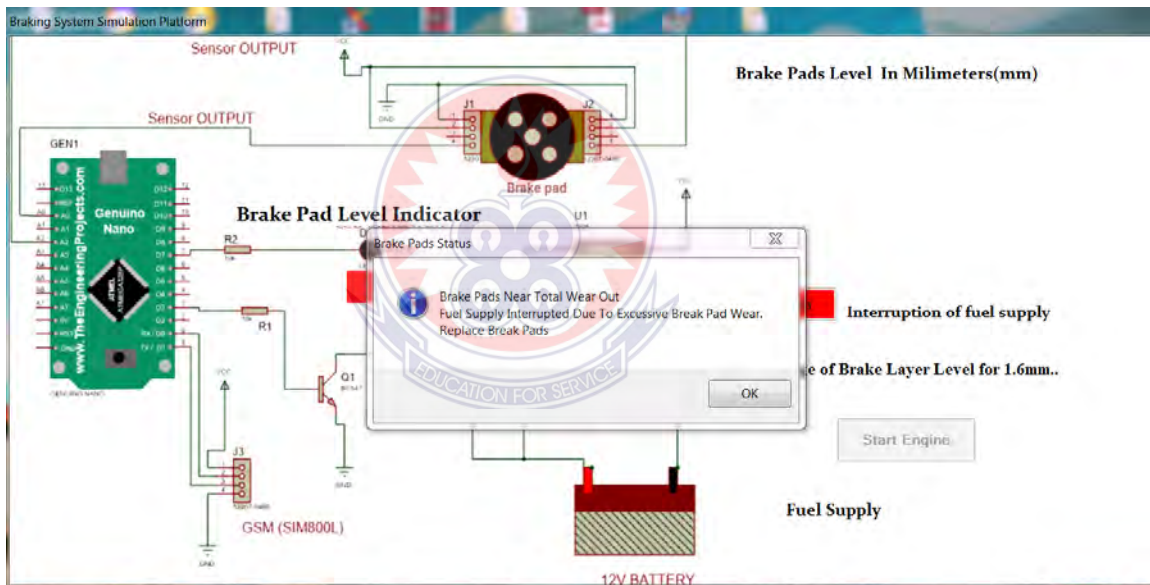
**Figure 4.2 Simulation for danger replace brake pad stage**

When the indicator started to glow red in the instrument panel at a rate of 10%, interruption of fuel supply started leading to jerking of the engine as shown in Figure 4.3.

This is the critical condition where the fuel supply line opens by the relay to cut off fuel from flowing into the engine due to worn brake pad and at a range from 1.8mm to 1.6mm for hydraulic brakes as shown in Figure 4.4.

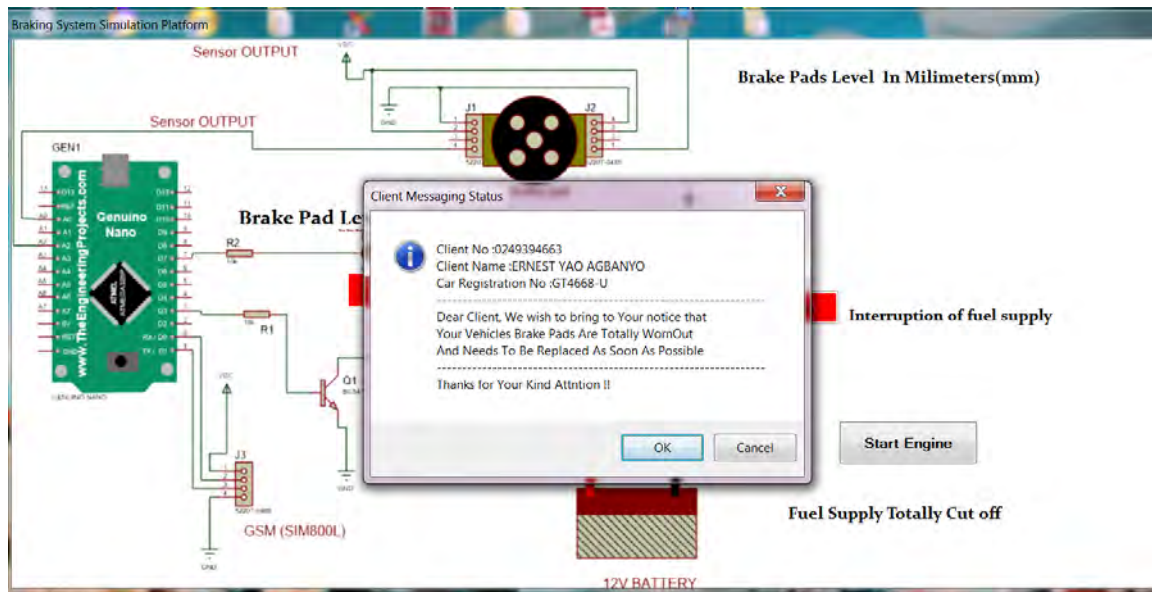


**Figure 4.3 Simulation for interruption of fuel supply line**



**Figure 4.4 Simulation for cut off fuel supply line and engine going off**

Text message showing on the instrumental panel and also on the driver's or owner of the vehicle's phone. Fuel supply cut off by the relay and vehicle cannot move until brake pad is replace as shown in Figure 4.5.



**Figure 4.5 Text message communication to driver/owner of the vehicle on conditions of brake pad**

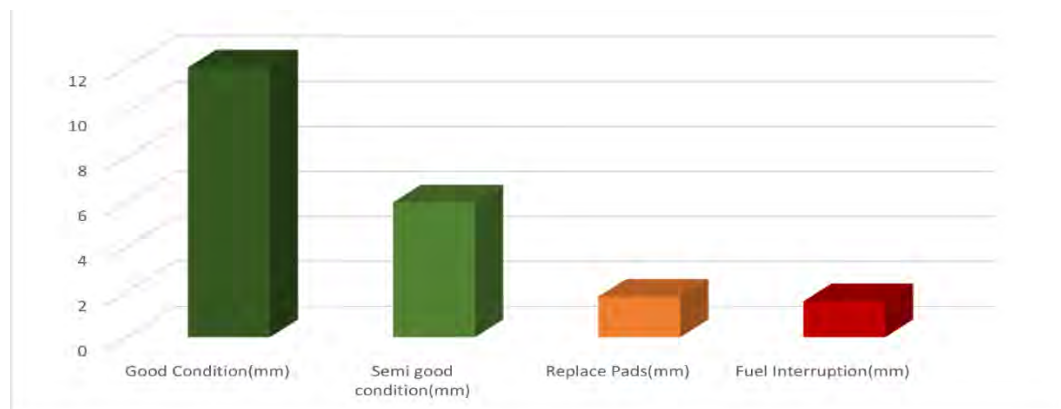
From the simulation, it could further be seen that as the brake pad wear increases; retardation or stopping distance also increases, which means both are directly proportional. This again means that when the brake pad is excessively worn it's gripping efficiency decreases leading to rear end collision.

This observation was further made after continuous use on brake testing equipment such as automated brake tester. For the brake pads to wear down to 1.6mm, it will take six to eight months of rigorous use of a vehicle and its brake application.

### 4.3 Brake Pad Wear Detection Parameters

The friction material on a new brake pad is typically about 8-12mm thickness, and those that are ready for replacement are worn down to 1.6mm for hydraulic brake according to Haynes & Haver's, (2019), repair service manual and as also shown in Figure 4.6. It is important to replace the pads before the friction material wears out

completely, as the pads steel backing plate will begin scoring/damaging the brake disc or rotor if contact continues.



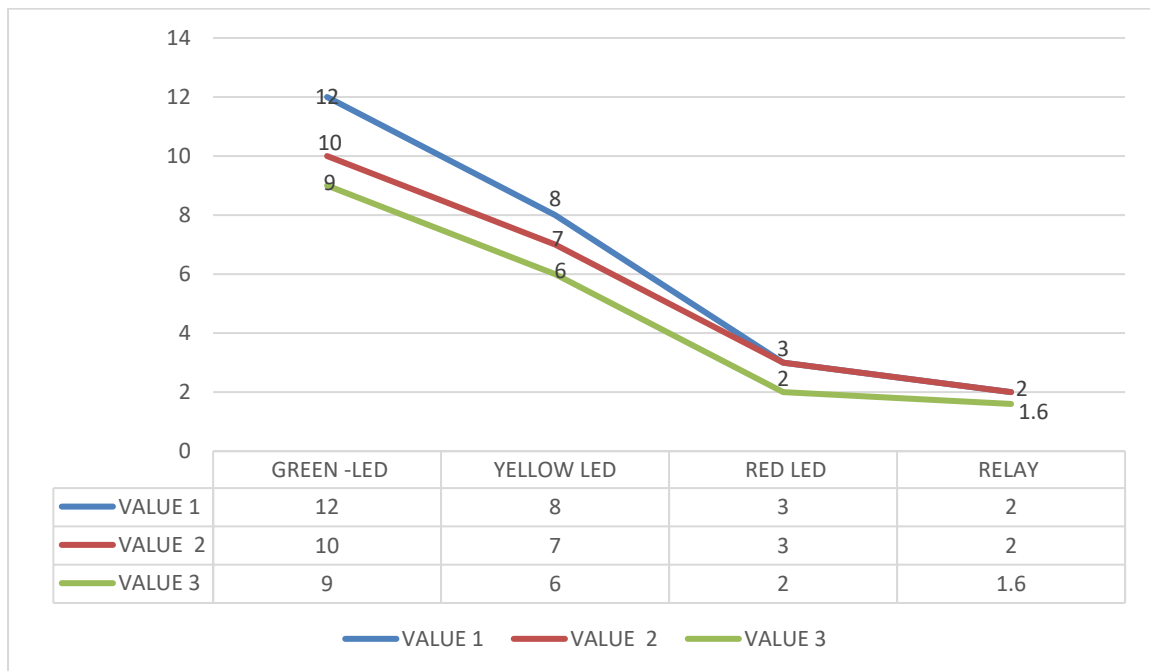
**Figure 4.6 Brake pads wear conditions or parameters**

Table 4.1. Shows the parameters and conditions on reading of the sensors and output result as compared to actual thickness size of 12mm and anything below is check by the sensor. These alerts light will appear on the instrument panel (dash board) in the form of blinking immediately the engine is crank and the brake pedal is step on.

**Table 4.1 brake pad wear alert conditions**

Brake pad thickness	Colour code	Alert message
12mm	Green led	Good condition
6mm	Green led	Semi good condition
1.8mm	Yellow led	Danger replace brake pad
1.6mm	Red led	Interruption of fuel supply
1.6mm	Red led	Relay open to stop fuel supply

The graph in Figure 4.7 shows how the system performs by responding to the information in Table 4.1.



**Figure 4.7 Brake pad wear**

#### 4.4 Brake pad service life

Brake pad thickness, stopping distance and cutting off fuel supply line are the three parameters which are measured and communicated by the proximity sensor together with the microcontroller or arduino pro mini mega328p as shown in Figure 3.1. The arduino is preloaded with formulae and algorithms based on input data in C language. The arduino received the data from the proximity sensor to calculate the data and predicts the brake pad service life remaining thickness. When the predicted brake pad thickness is nearer or equal to preloaded safe limit value 1.6mm of the brake pad, a warning light glows indicating the brake pad's replacement time.

## CHAPTER FIVE

### SUMMARY OF FINDINGS, CONCLUSIONS, RECCOMENDATIONS AND SUGGESTIONS

#### 5.1 Introduction

This chapter seeks to deal with the summary of findings, conclusion and recommendation for future research.

#### 5.2 Summary of findings

These observations were found;

- ❖ That, the promixity sensor detect the status of the brake pad as it approaches the set limit hence send a signal to arduino and microcontroller for text message to the driver/owner and interruption of fuel supply leading to stopping of the vehicle in order to avoid rear end collision accidents.
- ❖ That efficiency of the sensor in terms of detectability hit nearly 100%. This indicated that sustainable performance was expected for real time application for detection of brake pad wear.
- ❖ That once the brake indicator started to glow from yellow to red, the brakes were not as efficient as they were before and stopping distance had increased, be certain distance along with the driver effort. Hence call for vehicle stoppage to reduce road accidents.

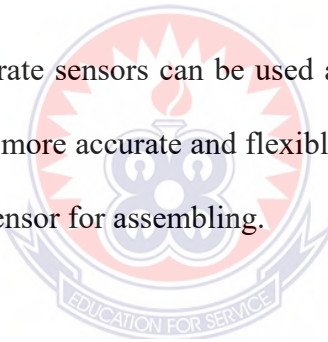
#### 5.3 Conclusions

This research is conducted with a view to design brake pads wear detection sensor with alarm alert, text messages to serve as a precautionary measure for drivers/car owners about the conditions of the brake pad and its efficiency, call for interruption or

shutting down of fuel supply line in order to stop the engine running to reduce rear-end collisions accidents if recalcitrant driver ignores the alert signals to replace or change the worn out brake pad.

Furthermore, this technology will enhance the braking system in the following ways.

1. The researcher deems it effective by giving audio visual indication when there is a mistake in braking system.
2. By devising a mechanism of this sort, driving will become safer, reliable and most importantly enhance the safety of occupants in the cars or vehicles who form the majority in any economy.
3. This technology will help in reducing the number of accidents on our roads due to braking system efficiency.
4. Smaller and more accurate sensors can be used apart from proximity sensor, such as eddy current sensor for more accurate and flexible result when there are constraints in looking for proximity sensor for assembling.



#### **5.4 Recommendations**

Based on the findings, the following are recommended;

- ❖ That car manufacturing companies should incorporate this design in vehicle during production and assembling of parts.
- ❖ That this design should be mass produced for every vehicle in order to reduce road accident.



### **5.5 Suggestion for future work**

- ❖ In future research, other means apart from interruption of fuel supply system can be used to shut down the engine when the brake pad is excessively worn.
- ❖ Also future design should be connected to anti- lock braking system to lock the wheels when there is excessive pad wear.



## REFERENCES

- Adeseko & Kareem, article published August, (2018), (p. 226-231), ([www.researchgate.net/publication/328688577](http://www.researchgate.net/publication/328688577)), *International Journal of Mechanics Engineering and Automation on performance optimization of non-disposable brake pad sensor; road traffic injuries and deaths.*
- Adams, F. September, (2005). *Brake monitoring and sensor system for sensing temperature and wear.* U.S. Patent Application Publication.
- Baldwin & White September 24, (2020). *Resistive wear sensor.* Patent number, 4646,001. Washington, DC: U.S. Patent and Trademark Office. [www.ijmert.org](http://www.ijmert.org).
- Chan, A.R. Hashmi, Lomash, S. & Naik, A. (2004). *Development of Asbestos Free Brake Pad Wear*, Vol.85, pp. 13-16.
- DIXCEL Company Limited manufactures of brake pads, sensors, and pad wear sensors.* ([www.dixcel.co.jp](http://www.dixcel.co.jp))
- Eriksson, M., Bergman, F. & Jacobson, S., (2000). *The effect of reduced contact area on the occurrence of disc brake squeals for an automotive brake pad.*
- Eriksson, M., & Jacobson, S., (2000) *Tribological Surfaces of Organic Brake Pads.* *Tribology International.* Vol.33, pp. 817-827.
- Eriksson, M., Bergman, F., & Jacobson, S., (2002). *On the nature of tribological contact in automotive brakes wear.* Vol. 252. Pp. 26-36.
- Ghana Government. National Road Safety Authority, (2019). *Annual Report. Ministry of Transportation.*
- Ghana Government. National Road Safety Authority, (2011). *Annual Report. Ministry of Transportation.*

- Ghana Government. Motor Traffic and Transport Department, (2018). Annual Report on Road Traffic Injury, Causes and Prevention in Ghana.
- Hanisk, P. & Adams, F. (2008). *Resistive brake lining wear and temperature sensing system*. United State. Patent Number: 5637794. Washington, DC; U.S. Patent and Trademark Office.
- Harshal B., Mayur M., Sham D., Dhanashri T. & Shraddha J. (2021). *Design and working of brake pad wear indicating system*. Vol.08. [www.ijrsred.com](http://www.ijrsred.com).
- Haver's, (2019), Auto repair guide manual.
- Hattwig, P., (2000), *Pad wear indication for disc brakes*. Volkswagenwerk, AG (West Germany).
- Hillier, V.A.W & Pittuck, P.K., *Fundamental of Motor Vehicle Technology* (2<sup>nd</sup> Edition, Section 18.1, p.479),
- Howell, M.N., Hills, R., White, J.P., Amatyakul, Jr.P., Chin, Y.K., Salman, M.A., Yen, C.H., & Riefe, M.T., October, 2(2008). *Brake pad prognosis system*. U.S Patent number 7694,555. Washington, DC: U.S. Patent and Trademark Office.
- <https://auto.howstuffworks.com/auto-parts/brakes/brake-problems/brake-failure1.htm>.
- <https://www.keyence.com/ss/products/sensor/sensorbasics/proximity/info/>.
- Kyrtsos, C., (2004). *Temperature sensing brake lining indicator*. U.S. Patent. Number. 5939978.
- Karim, N. (2000). *Brake pad wear indicator changing*.
- Kanishq & Parth, (2018). *Design of brake pad wear indicating system*.
- Lee, Y. S., Brooks, P. C., Barton, D. C., & Crolla, D. A., (2011). *Prediction of Disc Brake Contact Pressure Distributions*.
- Markel, A. June 7, (2016). *Brake pad wear sensors*. ([www.tomorrowstechnicians.com](http://www.tomorrowstechnicians.com))

Markel, A. April 1, (2020). *Electronic brake pad wear sensor*.(www.Bendix.com).

Mat L., Ahmad R., Abdul H., Mohd. K. & Abu B. A. R. (2018). *Brake pads surface composition./ design, construction and performance of a novel brake pad friction tester*.

Oduro, S.D., (2012). *Brake failure and its effect on road traffic accident in Kumasi Metropolis, Ghana*. International Journal of Science and Technology. Vol.09.

Osterle, W., & Urban, I., (2021). *Friction layers and friction films on PMC brake pads*.

Publication on September 29, (2005). *International Journal of Engineering Innovation and Research, a brake pad in a disc brake system is adapted to be moved against a rotating brake drum or disc brake disc*. (www.ijeirt.com)

Smith Repair, (2021).*Brake repair guide manual*.

Sarvendra K. M. & Jain, A.K. November (2013). *A review of experimental study of brake pad materials*, ISSN: 2249-6149.

Shailendra S., Yogesh J., Sahil G. & Verendra S. (2019). *Smart Braking System Using Ultrasonic Sensor and Actuator*. International Journal of Engineering and Technology. Vol. 06. (www.irjet.com).

Shubham G., Saurabh K., Muhammad M., Swaraj G. & Itkar, (2021). Overviews of brake pad wear indicator system: *A step toward “development of new brake pad wear indicating system”*. International Journal of Advance Scientific Research and Engineering Trends. Vol. 06.

Sivarao, M. Amarnath, Rizal, M.S., & Kamely, A., Oct. (2009). *Development of economical brake lining wear alert system*. International Journal of Engineering & Technology. IJET. Vol:09 No: 09.

- Sivarao, M. Amarnath, M.S. Rizal, M.S. & Kamely, A., Oct. (2009). *An investigation towards the development of brake lining wear alert system.* (1951091-ijet-ijens)
- Sivarao, M. Amarnath, Rizal, M.S. & Kamely, A., (2013). *Designed of non-commercial vehicle brake pads material.*
- Raybestos, (2018). *Vehicle with brake pad wear sensor/ original pad wear indicator.*  
Technical Bulletin 18-13 published by Brake Parts Inc.
- Towoju, O.A., February (2019), *Braking Pattern Impact on Brake Fade in an Automobile Brake System.* Journal of Engineering Sciences. Vol. 6.
- White, P. & Adams, F. (2005). *Brake monitoring and sensor system for sensing temperature and wear.* U.S. Patent number: 5559286. Washington, DC; Trademark Office.

